

Deluxe

Actual Size: 29.5x55x38

Seat Width: 19.75 inches

Shipping Size: 32x58x50

Shipping Weight: 295 lbs.

Net Weight: 215 lbs.

Water Capacity: 90 gal.

Occupied: 55-75 gal.

Drainage Time: +/- 80 sec at ideal home plumbing conditions (occupied)

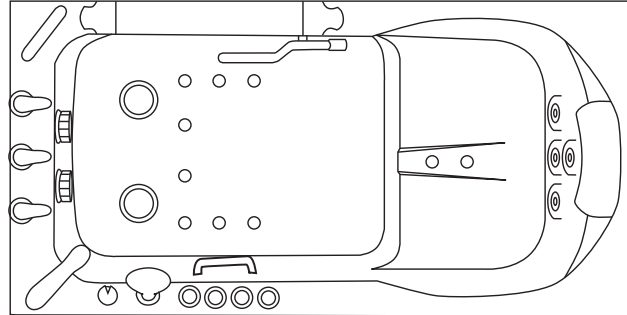

Included Features

- Acrylic Tub Shell:
 - High quality acrylic
 - Excellent color uniformity
 - High Gloss White Finish
 - Fiberglass Reinforced
- Stainless Steel Frame with Adjustable Leveling Legs
- Inward swing removeable brushed stainless steel door with tempered glass
- Two (2) front and one (1) end removable access panel
- Stainless steel chrome finish U-shape deck mount grab bar
- Stainless steel chrome finish wall mount grab bar
- Extension panel, filler for 60" alcove installations

Floor Drains - 2 Options

- Two (2) 2" PVC T-type two (2) outlet drain with endcaps Two (2) overflows and cable operated openers with extended handles for easier grip in chrome finish
- Two (2) 2" Brass threaded floor drains with copper overflow and cable operated opener with extended handle

Warranty

- Lifetime limited warranty on acrylic walk in tub shell, frame, and door
- 5 year parts warranty (please visit www.ellasbubbles.com for more detailed information)

Optional Jetting

(Please refer to diagrams below based on selected package)

- Hydro Massage System
 - Hydro Massage Pump 5AMP 600W
 - Hydro massage intensity dial air control
 - In-line water heater 5.5AMP 650W
 - Ozone Sterilization
 - Refer to technical drawing for jet count
- Air Massage System
 - Air Massage Pump 4.5AMP 486W
 - Refer to technical drawing for jet count
 - 3 Speed Pump
 - Autopurge (Activates 20 minutes after pump shutdown)

Optional Jetting

(Please refer to diagrams below based on selected package)

- MicroBubble Therapy System
 - 1HP Pump 10AMP 1200W
 - Pressure Vessel
 - On/Off Push Control
 - Agitator Valve
- Dual Jetting (Air + Hydro)
- Soaking (No Jetting Option)

Optional Features

- Heated Seat and Backrest 4AMP 470W
- LED Chromatherapy Light .04AMP (Hydro + Air Package)
- Aromatherapy
- On/Off Push Controls or Digital Controller

Faucet Options

- Five-Piece Thermostatic Control Valve Faucet Set**
 - 7-8 GPM (average) @ 60 PSI at ideal in home plumbing conditions
 - Two (2) 2-way diverters with extension handles
 - Pull out, hand held, chrome plated hand shower with 5 ft. retractable stainless steel braided hose
 - 1 year warranty
- Five-Piece Fast Fill Huntington Brass Faucet Set**
 - 14-18 GPM (average) @ 60 PSI at ideal in home plumbing conditions
 - Pull out, hand held, chrome plated hand shower with 5 ft. retractable stainless steel braided hose
 - 5 year warranty
 - visit www.huntingtonbrass.com/warranty for full warranty information
- Five-Piece Jandon Roman Faucet Set**
 - 14-16 GPM (average) @ 60 PSI at ideal in home plumbing conditions
 - Pull out, hand held, chrome plated hand shower with 5 ft. retractable stainless steel braided hose
 - 5 year warranty
 - visit <https://www.jandonfaucet.com/> for full warranty information

Electrical Requirements:

Please refer to Technical Diagrams for more information

Deluxe - Inward Swing Door Walk In Bathtub Drawing
with 2" T Type Dual Port Drain

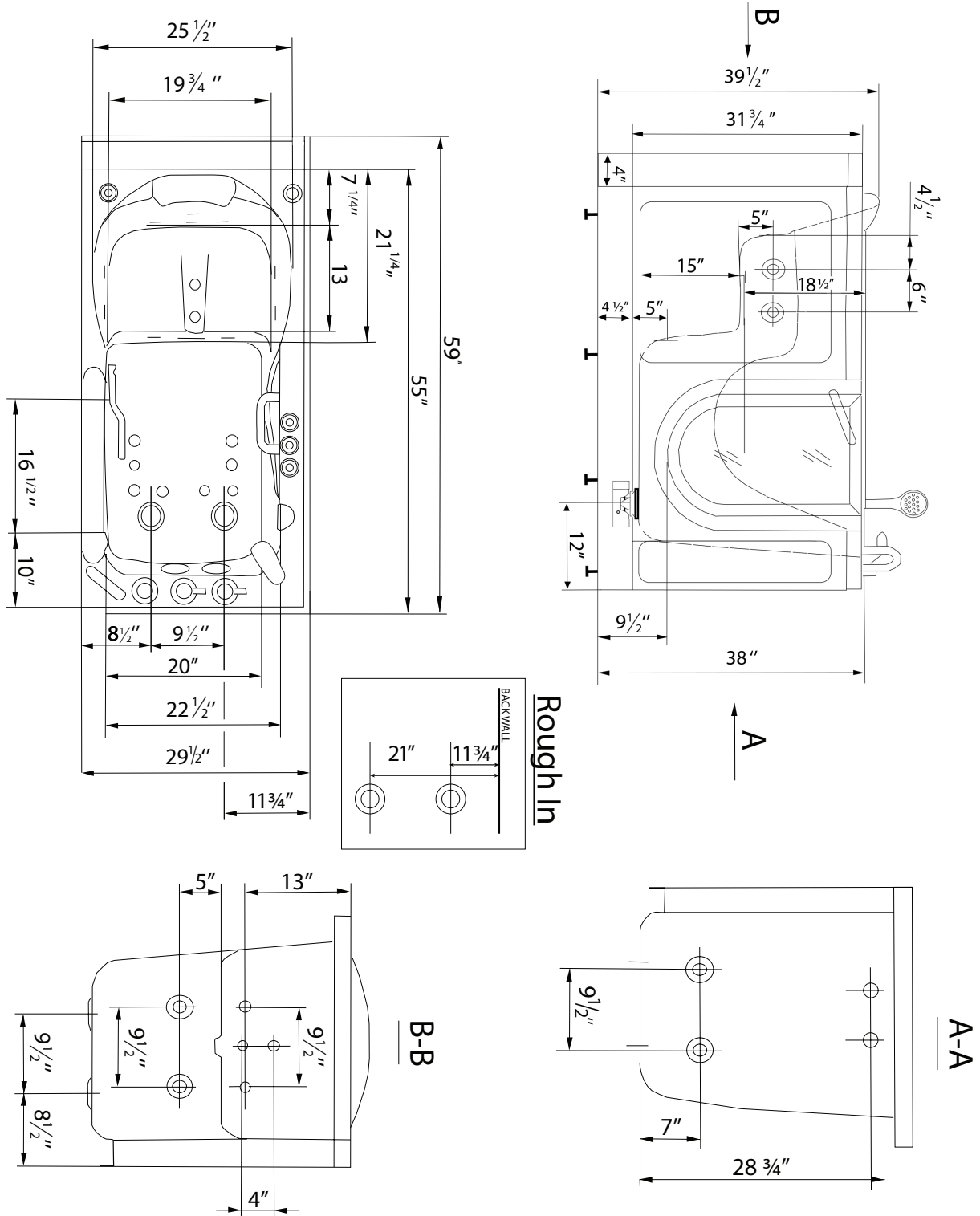

Hydro Massage + Air Massage
(Dual)

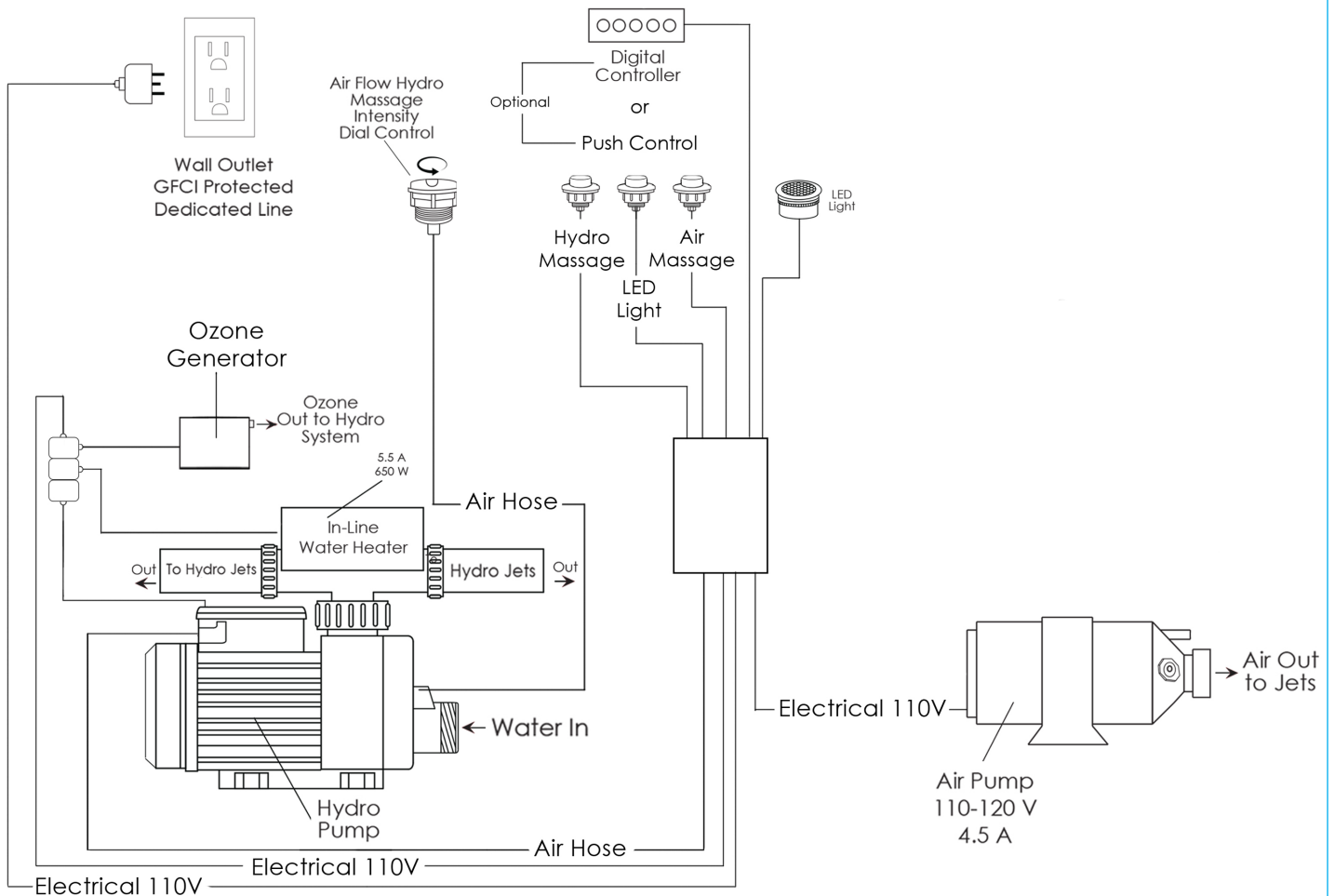

Package Jetting Information:

1. Hydro Massage System 5AMP 600W

- Refer to technical drawing for jet count
- Hydro Massage Air Flow Intensity Control
- In-line water heater 5.5AMP 650W
- Ozone Sterilization

2. Air Massage System 4.5AMP 486W

- Refer to technical drawing for jet count
- 3 Speed Pump
- Autopurge (Activates 20 minutes after pump shutdown)

Electrical Requirements:

One (1) dedicated 120V electrical line with a 20AMP GFCI standard three prong outlet is required

Hydro Massage + Air Massage + Infusion Microbubble Therapy

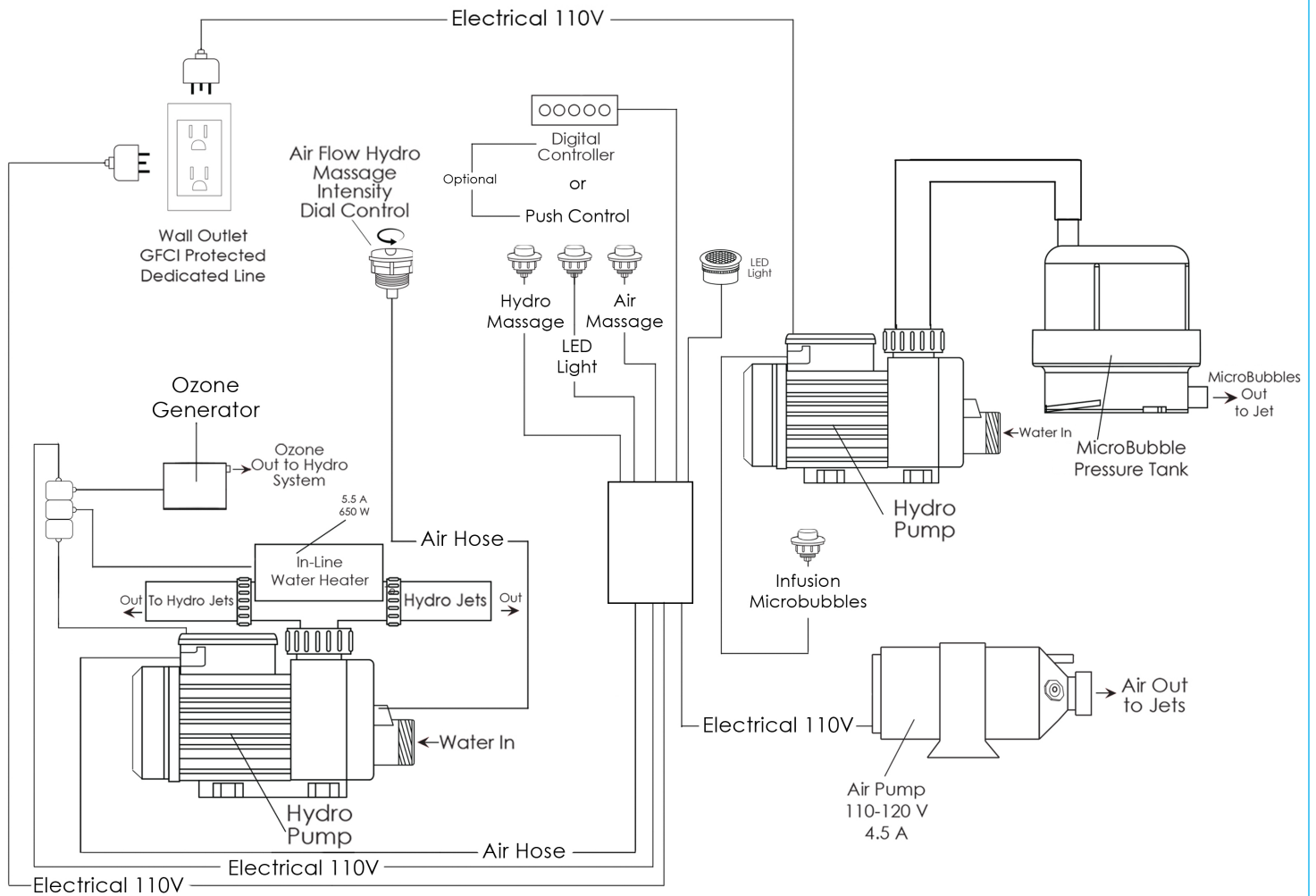

Package Jetting Information:

1. Hydro Massage System 5AMP 600W

- Refer to technical drawing for jet count
- Hydro Massage Air Flow Intensity Control
- In-line water heater 5.5AMP 650W
- Ozone Sterilization

2. Air Massage System 4.5AMP 486W

- Refer to technical drawing for jet count
- 3 Speed Pump
- Autopurge (Activates 20 minutes after pump shutdown)

3. MicroBubble Therapy System 10AMP 1200W

- 1HP Pump
- Pressure Vessel
- Air Switch and one (1) jet
- Agitator Valve

Electrical Requirements:

Two (2) dedicated 120V electrical lines with 20AMP GFCI standard three prong outlets are required

Hydro Massage

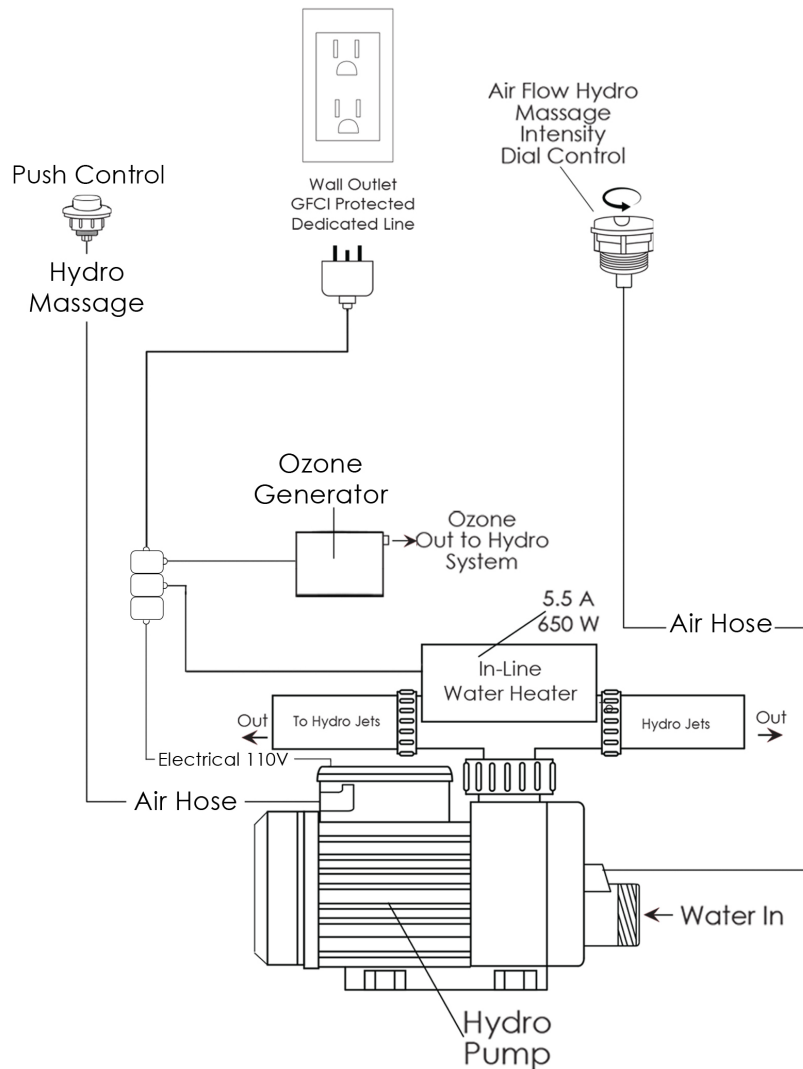

Package Jetting Information:

- Hydro Foot Massage System 5AMP 600W**
 - Refer to technical drawing for jet count
 - Hydro Massage Air Flow Intensity Control
 - In-line water heater 5.5AMP 650W
 - Ozone Sterilization

Electrical Requirements:

One (1) dedicated 120V electrical line with a 20AMP GFCI standard three prong outlet is required

Hydro Massage + Infusion Microbubble Therapy

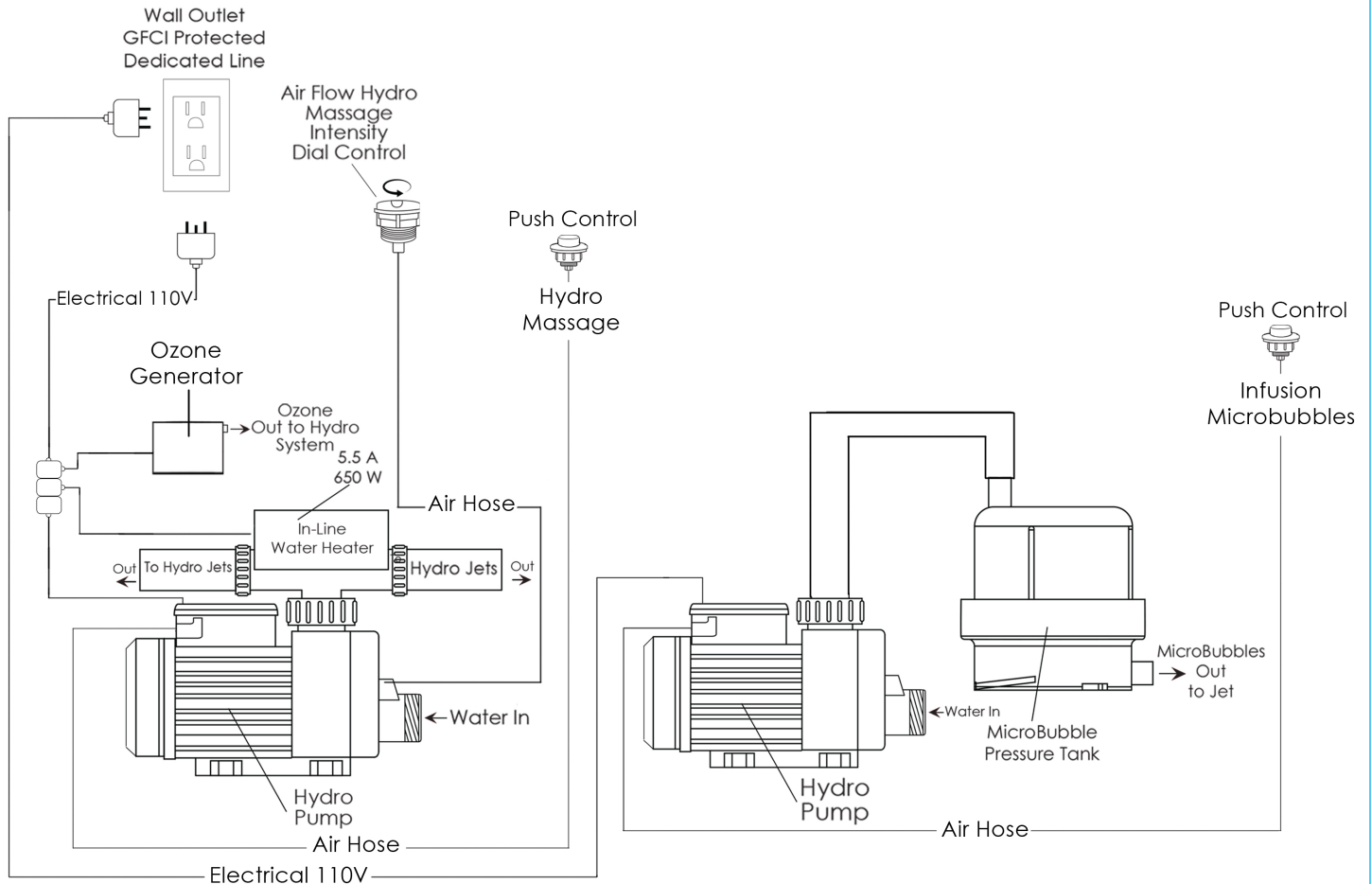

Package Jetting Information:

- 1. Hydro Massage System 5AMP 600W**
 - Refer to technical drawing for jet count
 - Hydro Massage Air Flow Intensity Control
 - In-line water heater 5.5AMP 650W
 - Ozone Sterilization
- 2. MicroBubble Therapy System 10AMP 1200W**
 - 1HP Pump
 - Pressure Vessel
 - Air Switch and one (1) jet
 - Agitator Valve

Electrical Requirements:

One (1) dedicated 120V electrical line with a 20AMP GFCI standard three prong outlet is required

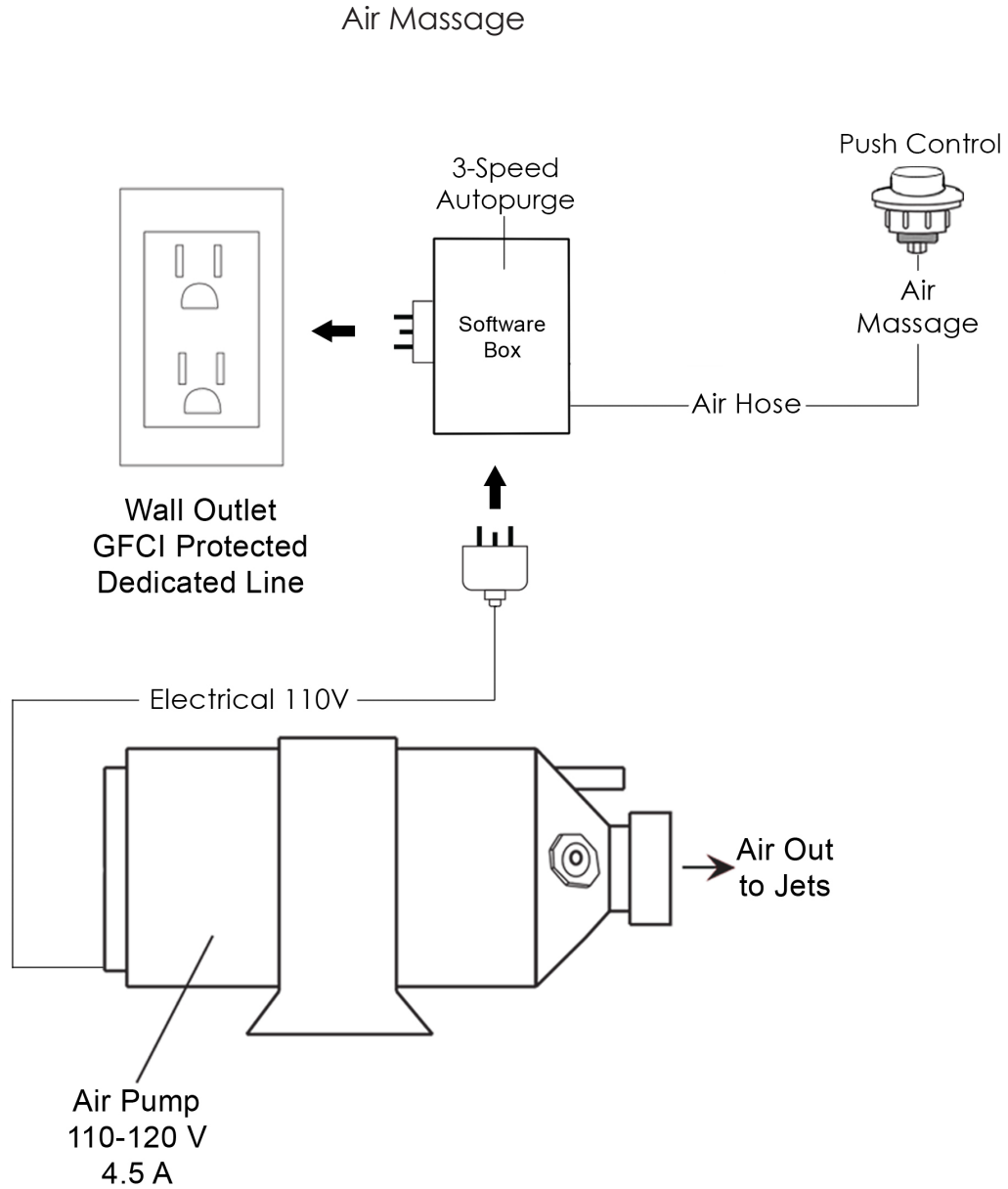

Package Jetting Information:

- 1. Air Massage System** 4.5AMP 486W
- Refer to technical drawing for jet count
 - 3 Speed Pump
 - Autopurge (Activates 20 minutes after pump shutdown)

Electrical Requirements:

One (1) dedicated 120V electrical line with a 15AMP GFCI standard three prong outlet is required

Air Massage + Infusion Microbubble Therapy

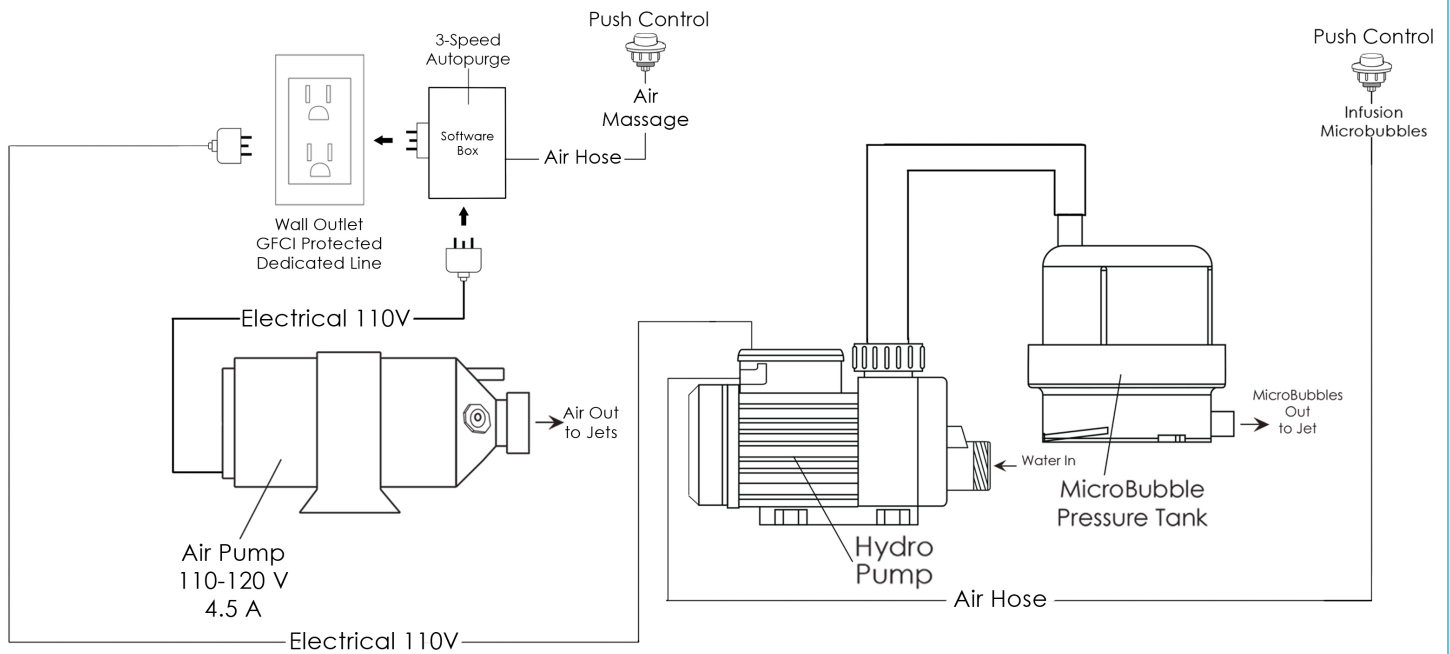

Package Jetting Information:

- 1. Air Massage System** 4.5AMP 486W
 - Refer to technical drawing for jet count
 - 3 Speed Pump
 - Autopurge (Activates 20 minutes after pump shutdown)
- 2. MicroBubble Therapy System** 10AMP 1200W
 - 1HP Pump
 - Pressure Vessel
 - Air Switch and one (1) jet
 - Agitator Valve

Electrical Requirements:

One (1) dedicated 120V electrical line with a 20AMP GFCI standard three prong outlet is required

Infusion Microbubble Therapy

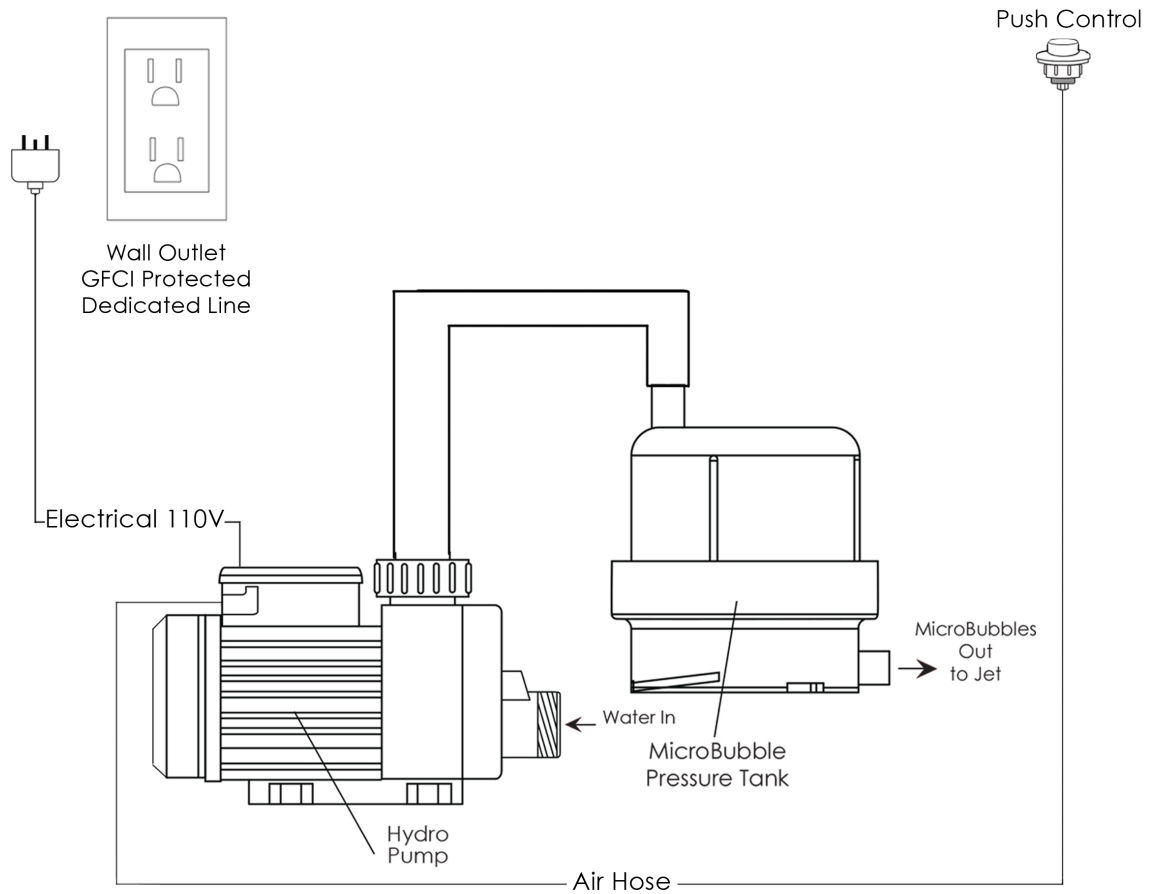

Package Jetting Information:

1. MicroBubble Therapy System 10AMP 1200W

- 1HP Pump
- Pressure Vessel
- Air Switch and one (1) jet
- Agitator Valve

Electrical Requirements:

One (1) dedicated 120V electrical line with a 20AMP GFCI standard three prong outlet is required